



FACILITY STUDY

for

Generation Interconnect Request GEN-2023-177

200MW Solar Generating Facility
Garvin County
Oklahoma

April 29, 2026

Rhiannon Hensley
Senior Engineer
Transmission Planning
OG&E Electric Services

Summary

Pursuant to the tariff and at the request of the Southwest Power Pool (SPP), Oklahoma Gas and Electric (OG&E) performed the following Facility Study to satisfy the Facility Study Agreement executed by the requesting customer for SPP Generation Interconnection request GEN-2023-177. The request for interconnection was placed with SPP in accordance with SPP's Open Access Transmission Tariff, which covers new generation interconnections on SPP's transmission system. The requirements for interconnection consist of building a new three terminal ring substation. Network upgrades at the new substation consist of installing switches, three breakers, metering, and associated equipment to connect to the Paoli to Seminole 138kV line. The total cost of OKGE is estimated at **\$13,735,207**.

Table of Contents

Table of Contents	3
Introduction	4
Interconnection Facilities	5
Interconnection Costs	6
One-Line diagram of Interconnection	7

Introduction

The Southwest Power Pool has requested a Facility Study for the purpose of interconnecting a solar generating facility within the service territory of OG&E Electric Services (OKGE) in Garvin County, Oklahoma. The proposed 138kV point of interconnection is a new substation on the Paoli to Seminole 138kV line in Garvin County. This substation will be owned by OKGE. The cost for installing a new three terminal 138kV substation, is estimated at **\$13,735,207**.

Network Constraints in the Southwest Public Service (SPS), OKGE and Western Farmers Electric Cooperative (WFEC) systems may be verified with a transmission service request and associated studies.

Other Network Constraints in the American Electric Power West (AEPW), Southwest Public Service (SPS), OKGE and Western Farmers Electric Cooperative (WFEC) systems may be verified with a transmission service request and associated studies.

Interconnection Facilities

The primary objective of this study is to identify attachment facilities. The requirements for interconnection consist of installing a new 138kV terminal and associated metering equipment at a new substation. This 138kV addition shall be constructed and maintained by OKGE. It is assumed that obtaining all necessary right-of-way for the line to the new 138kV substation will be performed by the interconnection customer.

The total cost for OKGE to add a new 138kV terminal in a new substation, the interconnection facility, is estimated at **\$3,759,390**. This cost does not include the building of the 138kV line from the customer substation into the new substation. This does not include the Customer's 138-34.5kV substation and the cost estimate should be determined by the Customer.

This Facility Study does not guarantee the availability of transmission service necessary to deliver the additional generation to any specific point inside or outside the Southwest Power Pool (SPP) transmission system. The transmission network facilities may not be adequate to deliver the additional generation output to the transmission system. If the customer requests firm transmission service under the SPP Open Access Transmission Tariff at a future date, Network Upgrades or other new construction may be required to provide the service requested under the SPP OATT.

The costs of interconnecting the facility to the OKGE transmission system are listed in Table 1.

Short Circuit Fault Duty Evaluation

It is standard practice for OG&E to recommend replacing a circuit breaker when the current through the breaker for a fault exceeds 100% of its interrupting rating with re-closer de-rating applied, as determined by the ANSI/IEEE C37.5-1979, C37.010-1979 & C37.04-1979 breaker rating methods.

For this generator interconnection, no breakers were found to exceed their interrupting capability after the addition of the Customer’s 200 MW generation and related facilities. OG&E found no breakers that exceeded their interrupting capabilities on their system. Therefore, there is no short circuit upgrade costs associated with the GEN-2023-177 interconnection.

Table 1: Required Interconnection Network Upgrade Facilities

Facility	ESTIMATED COST (2025 DOLLARS)
Lead time	36 Months
OKGE – Interconnection Facilities (UID 158949) - New 138kV terminal, metering equipment consisting of CT/PTs, and associated equipment	\$3,759,390
OKGE – Network Upgrades (UID 158077) - install 3- 138kV 3000A breakers, 2 terminals for the Paoli – Seminole Line, line relaying, switches, and associated equipment	\$9,975,817
OKGE – Land or ROW –	\$0
Total	\$13,735,207

Prepared by Rhiannon Hensley
Senior Engineer, Transmission Planning
OG&E Electric Services

April 29, 2026

Reviewed by:
Adam Snapp, P.E.
Senior Manager, Transmission Planning

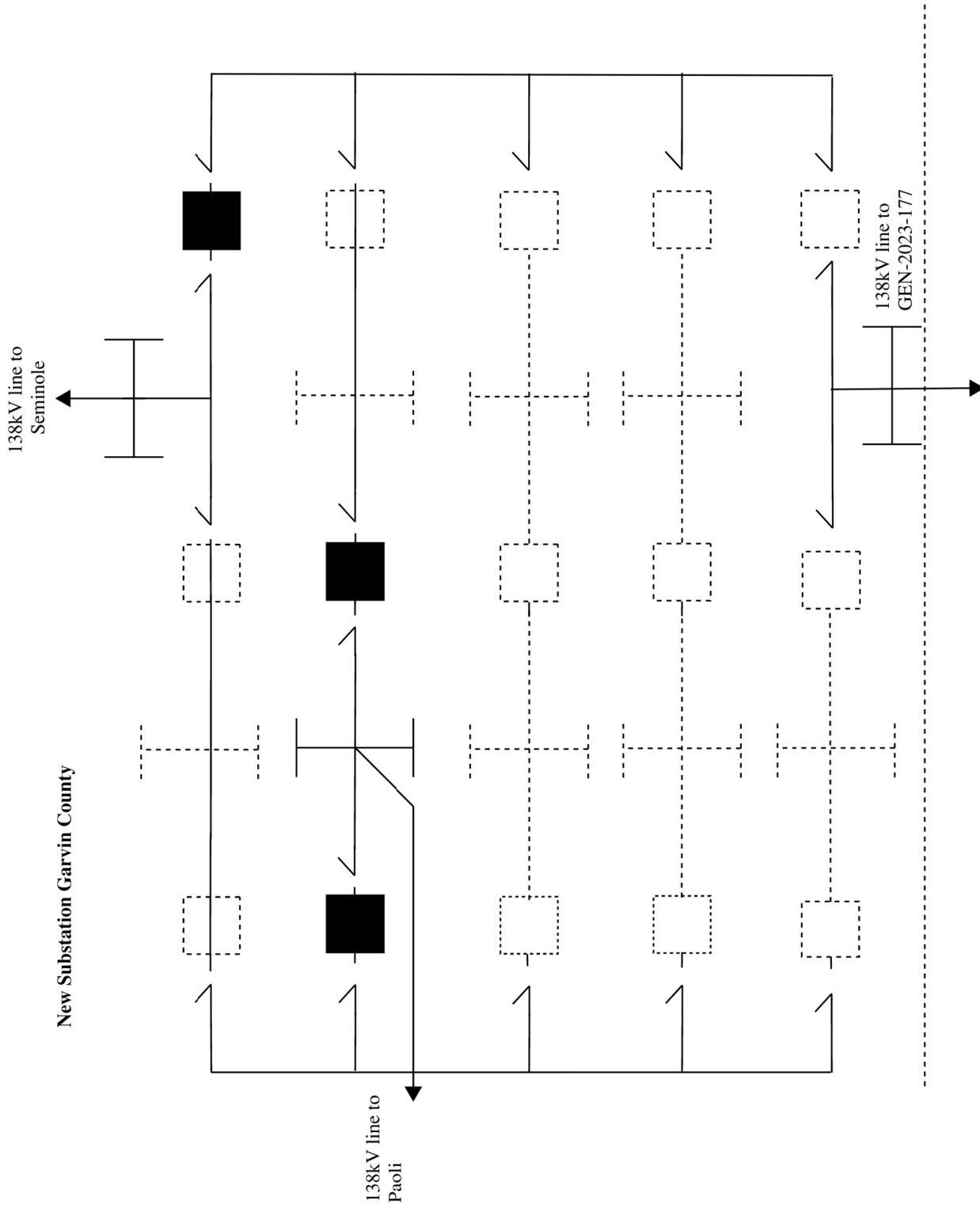

New Substation Garvin County